

REVISIONS

REV	DESCRIPTION	DATE	APPROVED

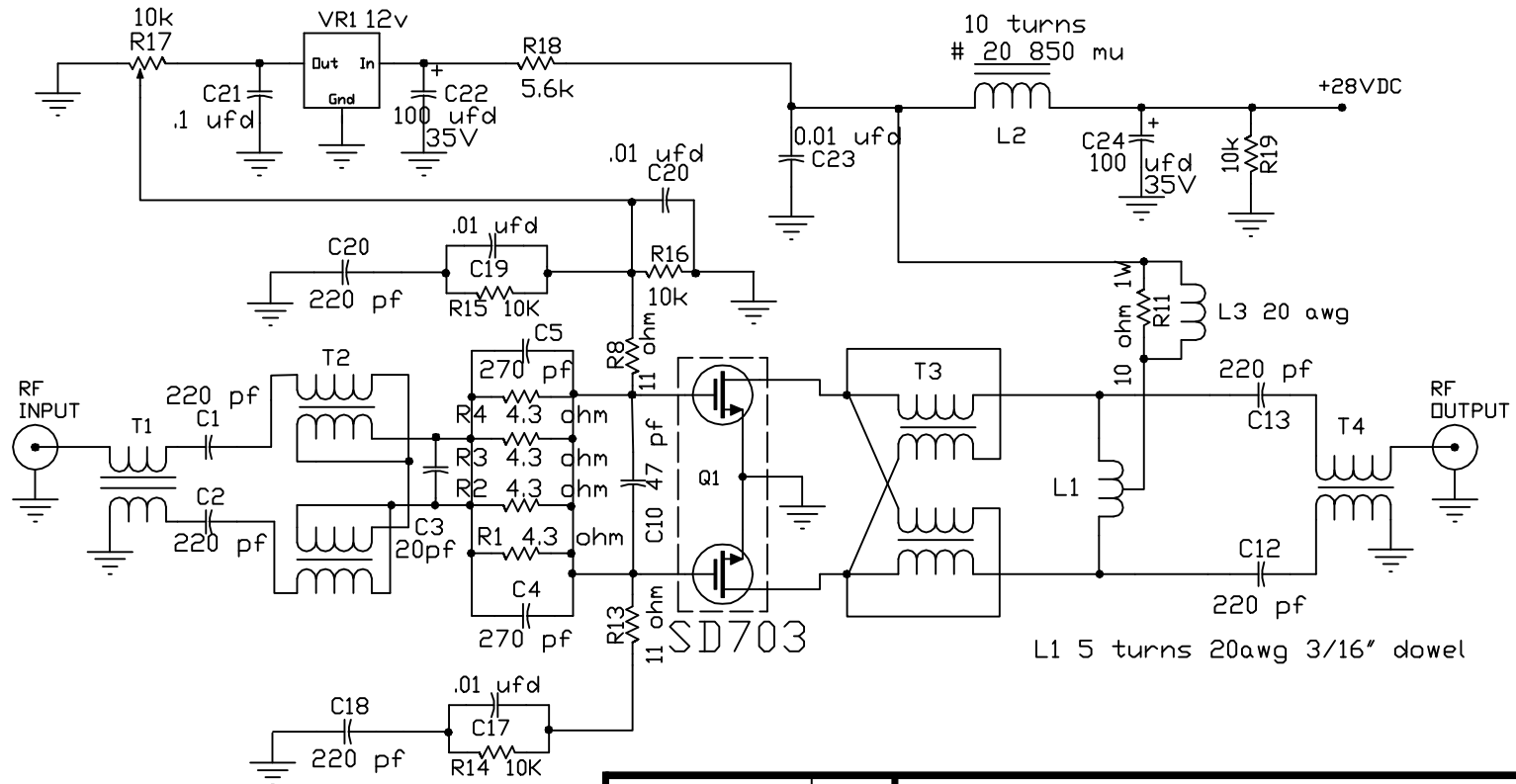

Resistors in Ohms

T1 2.8" long 50 ohm 0.048" O.D.

T2 2.8" long 18 ohm 0.062" O.D.

T1 & T2, in Ferrite. Amidon 12-365-K 125 mu

T3 3.3" long 10 ohm 0.075" O.D.

T4 50ohm 0.087" out dia 5 turns 3/8" dowel

DRN BY S. K. LEONG	5/15/99	POLYFET RF DEVICES	
CHKD		SCHEMATIC	
ELECT		200-400 Mhz 100W Amplifier	
MECH		SIZE A	FSCM ND. TB-127
PRDC			REV
QUAL		SCALE:	SHEET OF
PGMS			

SD703 TB-127 POUT VS FREQ ; IDQ=1.6A; VDS=28V

