

TB191 Pout/Gain vs Pin f=850MHz Vds=28Vdc Idq=.8A

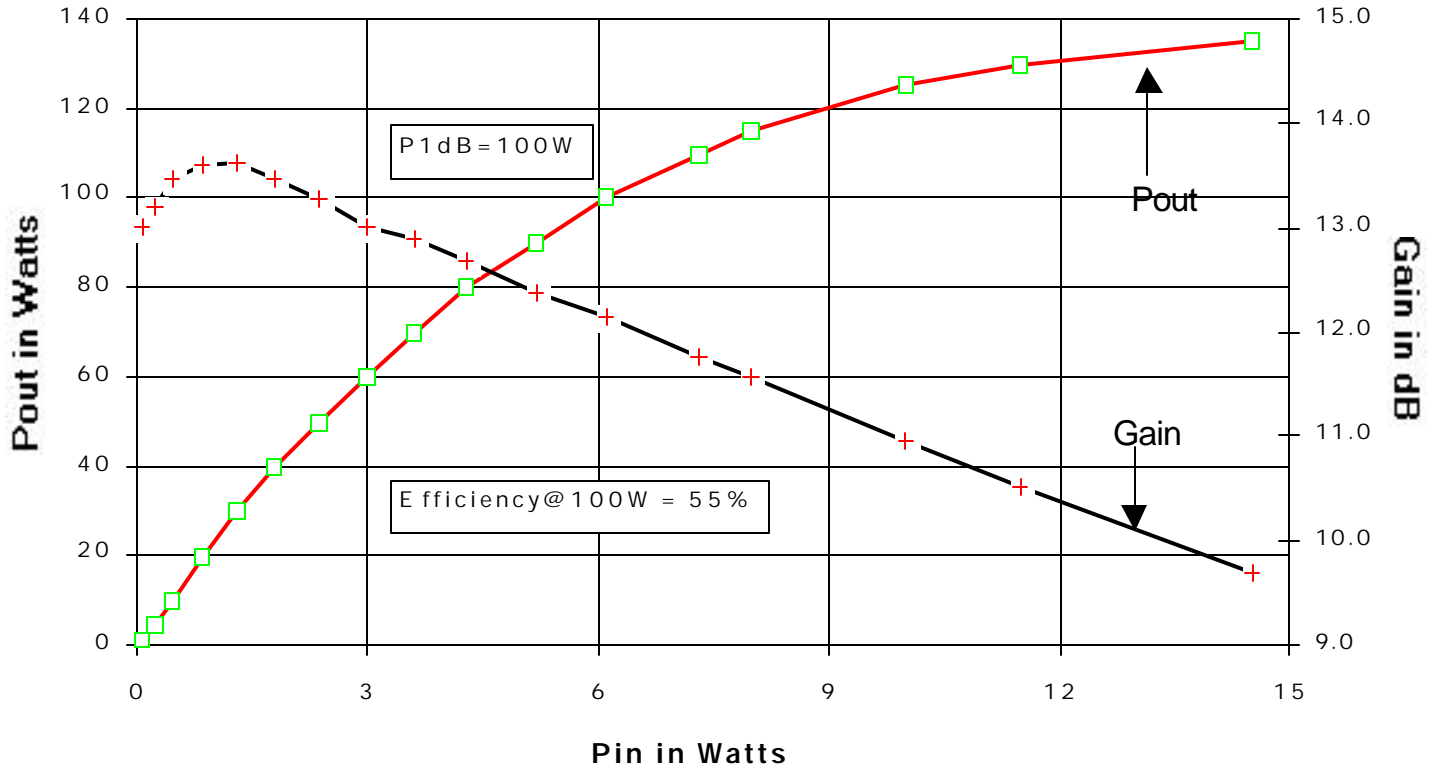

TB191 Gain/Efficiency vs Freq Vds=28Vdc Idq=.8A

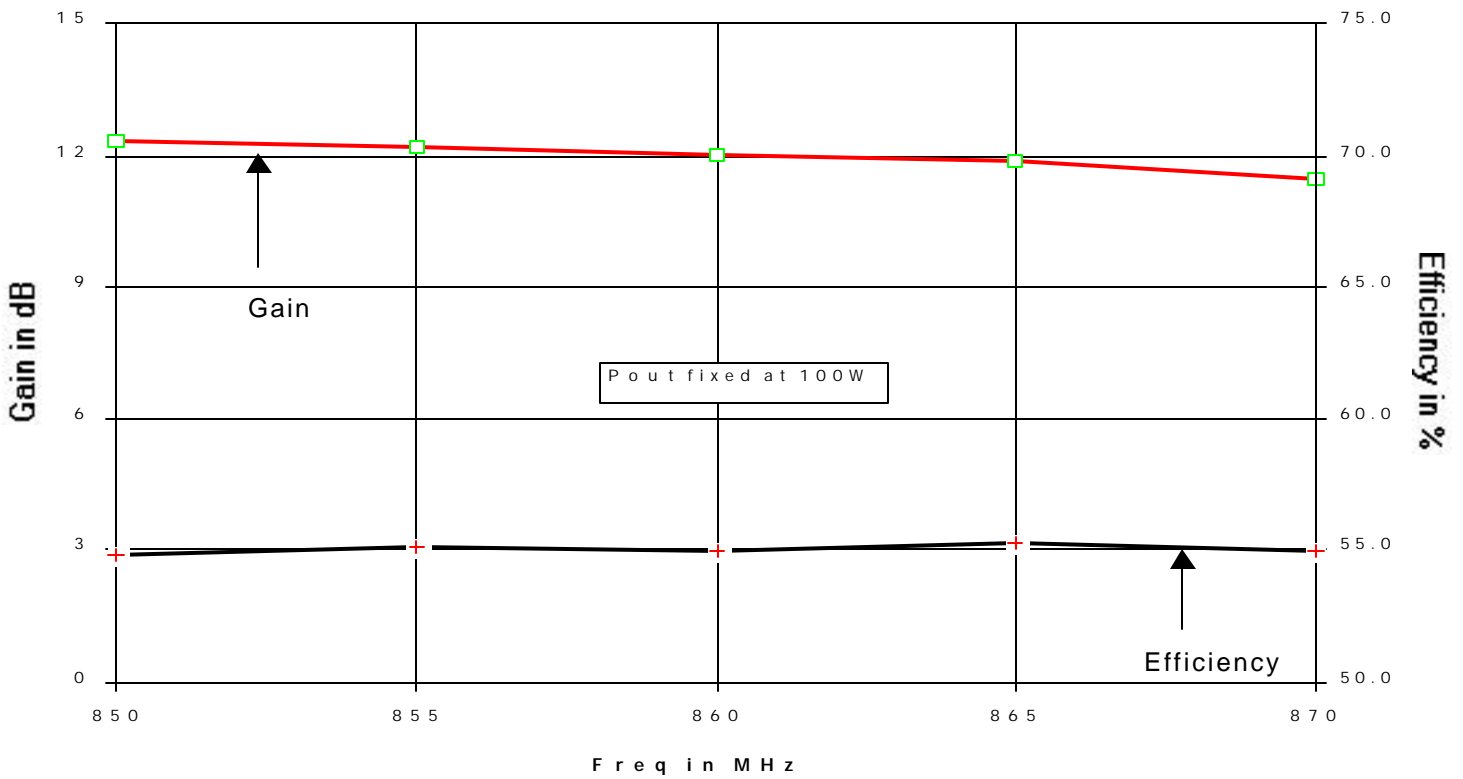

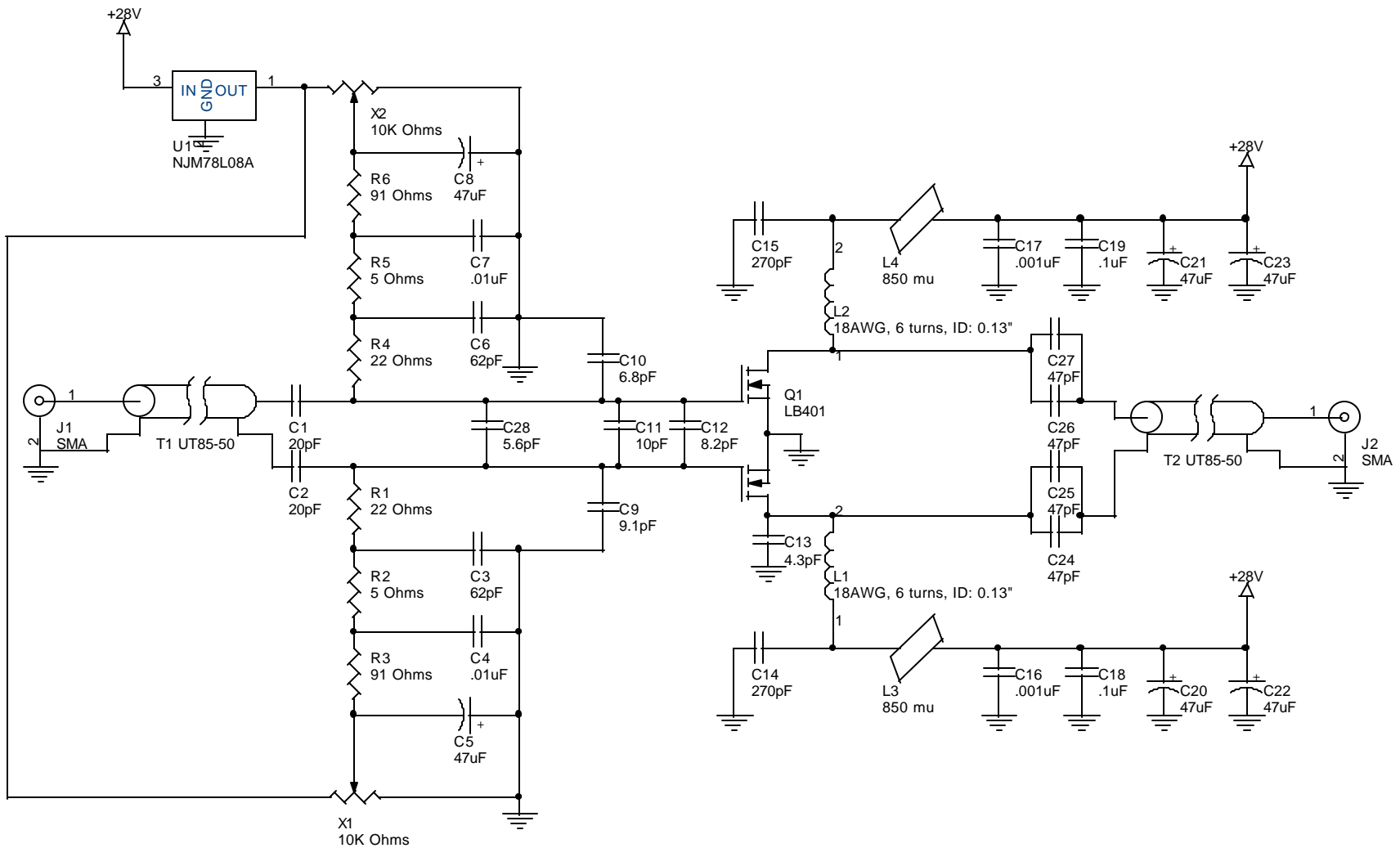

Title		
TB191 LB401		
Size	Document Number	Rev
A	Vds=28V Idq=0.8A f= 850-870MHz P1dB=100W Gain = 10 dB	
Date:	Thursday, September 09, 2004	Sheet 1 of 1

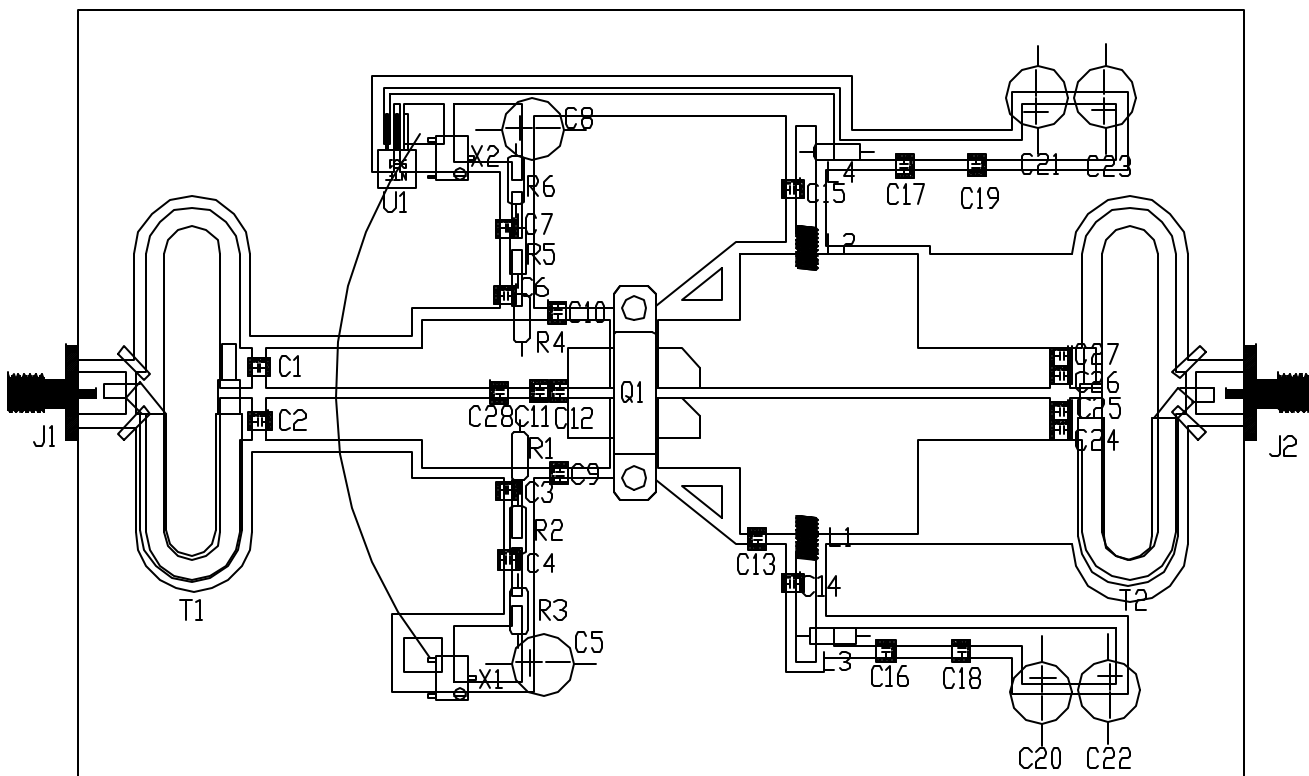

SYMBOL	VALUE	DESCRIPTION
C1, C2	20pF	ATC100B Capacitor
C3, C6	62pF	ATC100B Capacitor
C4, C7	.01uF	ATC200B Capacitor
C5, C8, C20 - C23	47uF	Electalytic 63V Capacitor
C9	9.1pF	ATC100B Capacitor
C10	6.8pF	ATC100B Capacitor
C11	10pF	ATC100B Capacitor
C12	8.2pF	ATC100B Capacitor
C13	4.3pF	ATC100B Capacitor
C14, C15	270pF	ATC100B Capacitor
C16, C17	.001uF	ATC700B Capacitor
C18, C19	.1uF	ATC100B Capacitor
C24 - C27	47pF	ATC100B Capacitor
C28	5.6pF	ATC100B Capacitor
J1, J2	---	SMA Connector
L1, L2	---	18AVG, 6 turns, ID: 0.13"
L3, L4	850mu	Axial RF Choke
R1, R4	22 Ohms	1/4W Axial
R2, R5	5 Ohms	1/4W Axial
R3, R6	91 Ohms	1/4W Axial
T1, T2	UT85-50	Semi-rigid Coax
U1	8V100mA	NJM78L08A
X1, X2	10K Ohms	POT 6mm Multi-turn
Q1	LB401	Polyfet Transistor
Vds	28V	Drain-to-Source Voltage
Idq	.8A	Quiescent Drain Current

DRN BY: TChang	09/09/2004	POLYFET RF DEVICES		
CHKD : TChang	09/09/2004			
ELECT :		TB191 850-870MHz P1dB=100W Gain=10dB		
MECH :		SIZE	FSCM NO	REV
PRDC :		PCB LAYOUT		1
QUAL :		SCALE : 1 : 1	SHEET 1 OF 1	
PGMS :				

