

TB197 L8821P Gain/Eff. vs Freq.; Vds=12.5Vdc Idq=0.2A

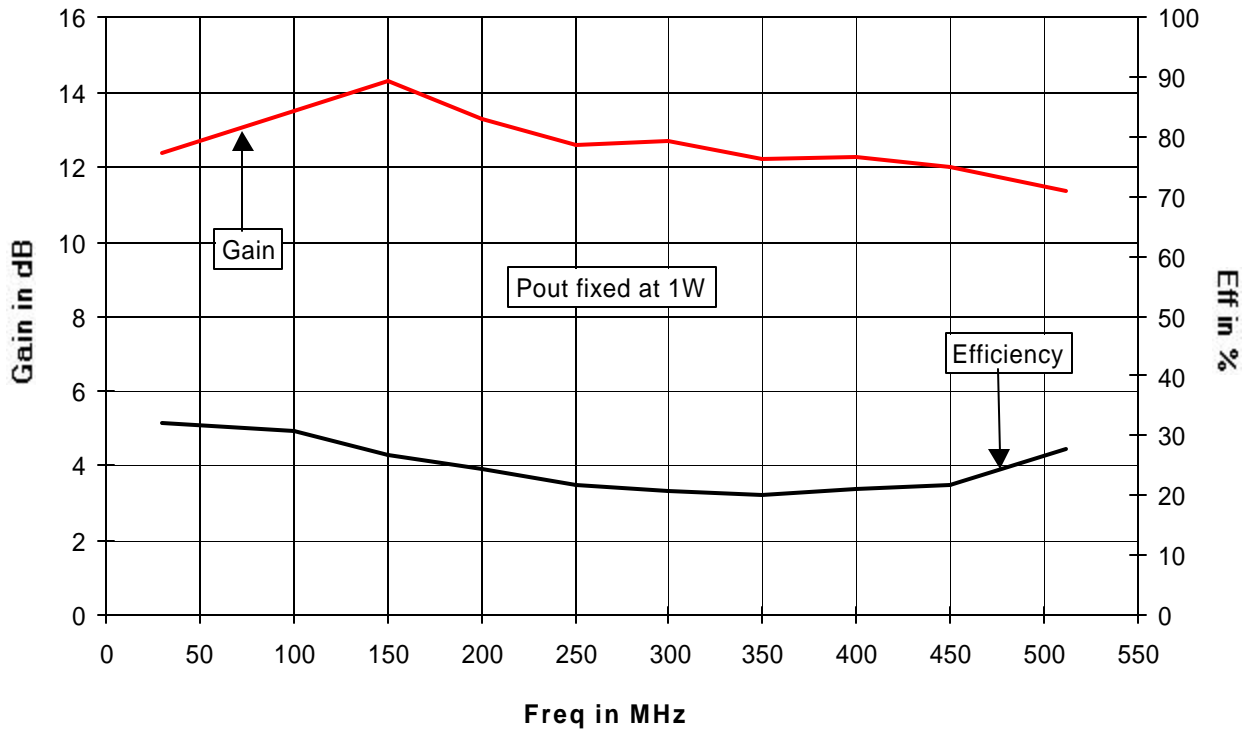

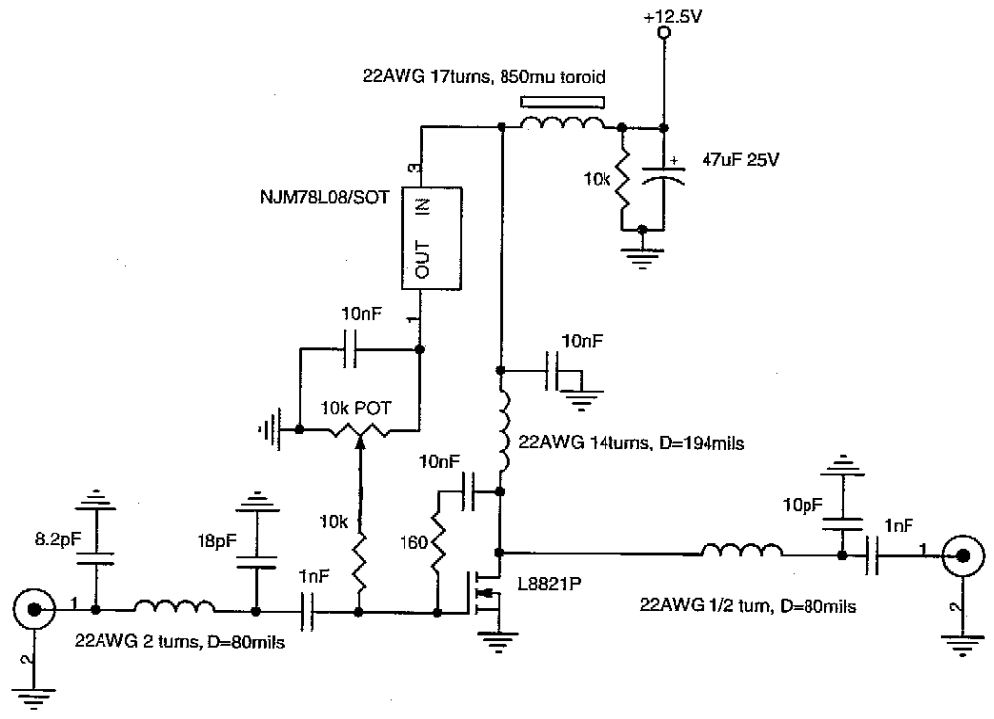

Title		
L8821P, 12.5V, 200mA Idq, 30-512MHz, 2W P1dB		
Size	Document Number	Rev
A	TB197	0
Date:	Wednesday, March 02, 2005	Sheet 1 of 1
2		1

